



MINI EXCAVATOR RANGE

# SY18C



# SANY

The SANY SY18C is extremely powerful and demonstrates outstanding stability in all situations. This machine meets all the expectations of its users thanks to having a robust design and being easy to service.

- » Quiet and low-vibration engine
- » Efficient, powerful load-sensing hydraulic system
- » Responsive, precise control
- » Ergonomic, comfortable seat
- » Clear instruments and large, high-resolution colour display
- » Optimum visibility
- » Powerful heating

## SY18C-TIER 4F(EU)

 OPERATING WEIGHT:

**1825kg**

 ENGINE MODEL:

**Yanmar 3TNV74F**

 WARRANTY:

**5 Year / 5,000 Hour**

[WWW.SANYHM.COM.AU](http://WWW.SANYHM.COM.AU)

QUALITY CHANGES THE WORLD

## SY18C DIMENSIONS & SPECIFICATIONS

### OVERALL DIMENSIONS

A	Transport Length	3575 mm
B	Transport Width	980 / 1350 mm
C	Overall superstructure width	980 mm
D	Overall height above cab	2,420 mm
E	Rear length	920 mm
F	Track width	750/1,120 mm
G	Undercarriage length	1,585 mm
H	Undercarriage width	980/1,350 mm
I	Blade height	270 mm
J	Track link width	230 mm
K	Tail swing radius	920 mm
L	Distance (centre) between crawler wheel and guide wheel	1,220 mm
M	Boom length	1,810 mm
N	Bucket arm length	1,130 mm

### WORKING RANGE

a	Max. horizontal reach on the ground	4,000 mm
b	Max. excavation depth	2,360 mm
c	Max. vertical reach	3,665 mm
d	Max. dumping height	2,635 mm
e	Min. slewing radius	1,655 mm
f	Max. excavation depth, vertical wall	2,215 mm
g	Working machine height at min. slewing radius	2,745 mm

### MACHINE PARAMETERS

Operating Weight	1,820/1,920 kg
Type	Water-cooled four-stroke diesel engine with turbulence chamber fuel injection
Rated power	11.2 kW
Max. torque	51.8 Nm/1,800 upm
Displacement	0.993 l
Main pumps	1 Adjustable axial piston pump
Maximum oil flow	1 x 55 l/min
Travel drive	2 Adjustable axial piston pumps
Slewing gear	1 Adjustable axial piston pump
Slewing speed	10 rpm
Max. ground speeds	fast 3.7 km/h slow 2.1 km/h

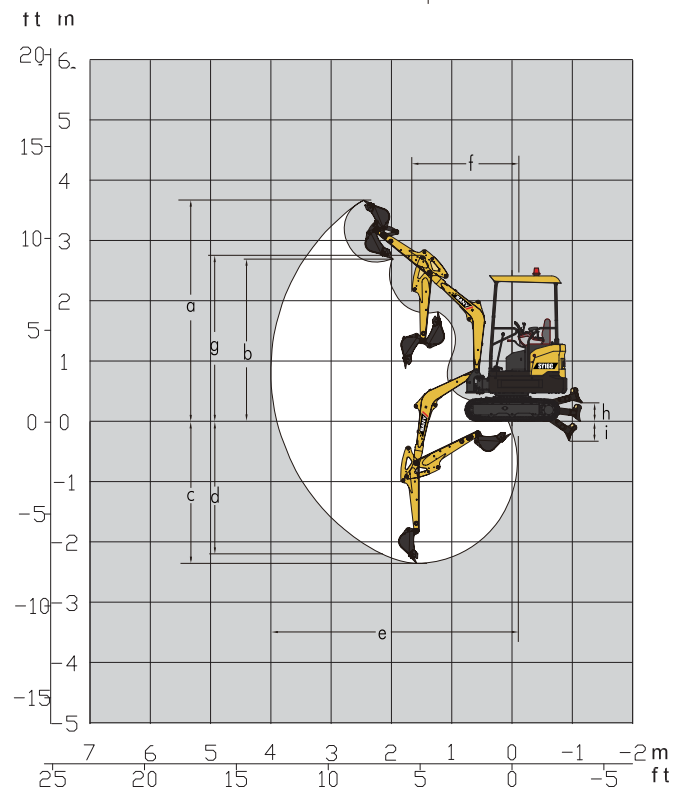
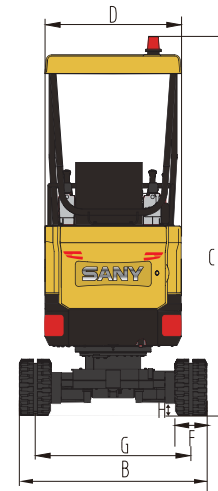
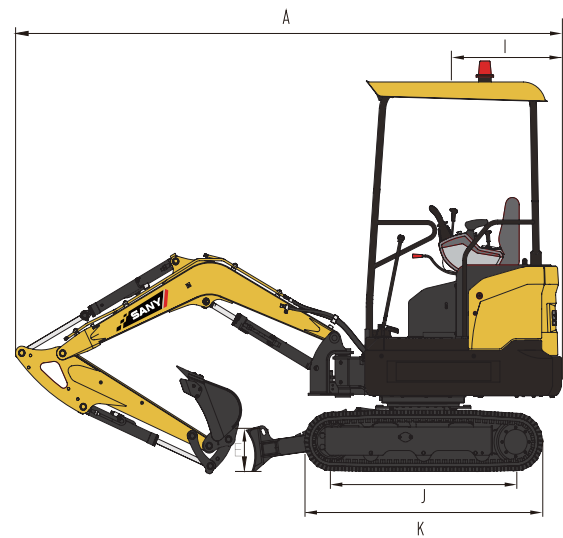

Not all products are available in all markets. Under our policy of continuous improvement, Sany reserve the right to change specifications and design without prior notice. The illustrations do not necessarily show the standard version of the machine.

**SANY HEAVY MACHINERY (AUSTRALIA)**

21 EFFICIENT DRIVE, TRUGANINA VIC 3029

PHONE 0400 724 483 [WWW.SANYHM.COM.AU](http://WWW.SANYHM.COM.AU)



**SANY**